

Instruction page index:

Scout vertical installation 2 - 3
Wiring Diagram 4

Installation Instructions for Scout Vertical

Models SCT-VRXX-XX

Please read all instructions prior to installation and keep for future reference!

1. Product to be installed by a qualified electrician.
2. Prior to installation ensure power is off at fuse box to prevent electrical shock.



7777 N. Merrimac Ave
Niles, IL 60714
T 224.333.6033
F 224.757.7557
info@luminii.com
www.luminii.com



Page 2 of 4

1

Note: More than one person is recommended for this install.

1.1 Carefully, place canopy on a flat surface, and remove the 3 screws from the canopy. Take the backplate off completely.

1.2 Remove the crossbar assembly from the backplate.

2

2.1 Feed the fixture wires through the rigid stem, then tighten to secure into the endcap.

3

3.1 Align the canopy female knuckle to the stem male knuckle and feed the fixture wires through into the canopy. Followed by securing together, reference diagram above to secure.

4

4.1 Insert the power wires into the crossbar assembly, backplate, lock washer and hex nut.

4.1 Align the crossbar assembly to the junction box holes and secure using the provided two #8-32 screw.

4.2 Slide the backplate up to the crossbar and secure by tightening the lock washer & hex nut into the crossbar nipple.

Installation Instructions for Scout Vertical

Models SCT-VRXX-XX

Please read all instructions prior to installation and keep for future reference!

1. Product to be installed by a qualified electrician.
2. Prior to installation ensure power is off at fuse box to prevent electrical shock.



7777 N. Merrimac Ave
Niles, IL 60714
T 224.333.6033
F 224.757.7557
info@luminii.com
www.luminii.com



Page 3 of 4

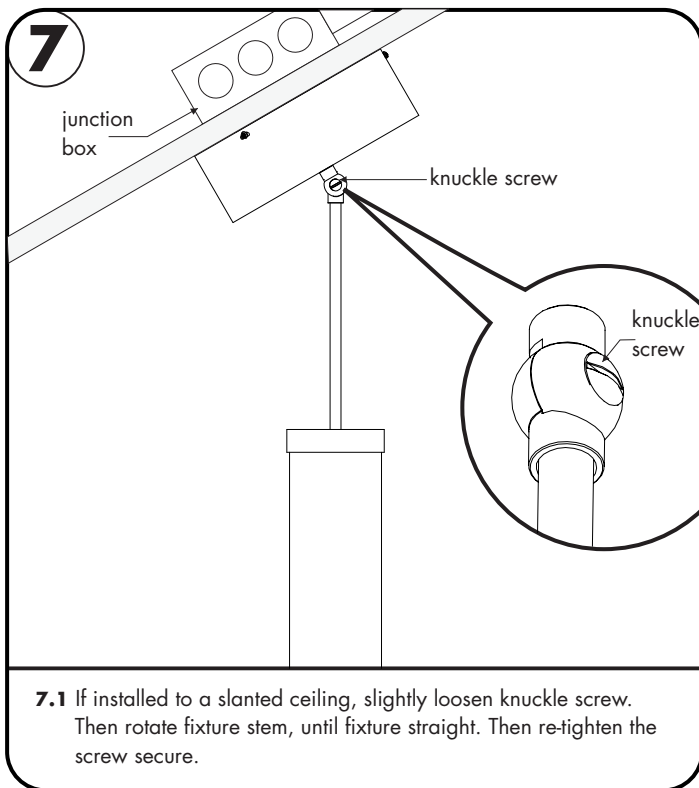
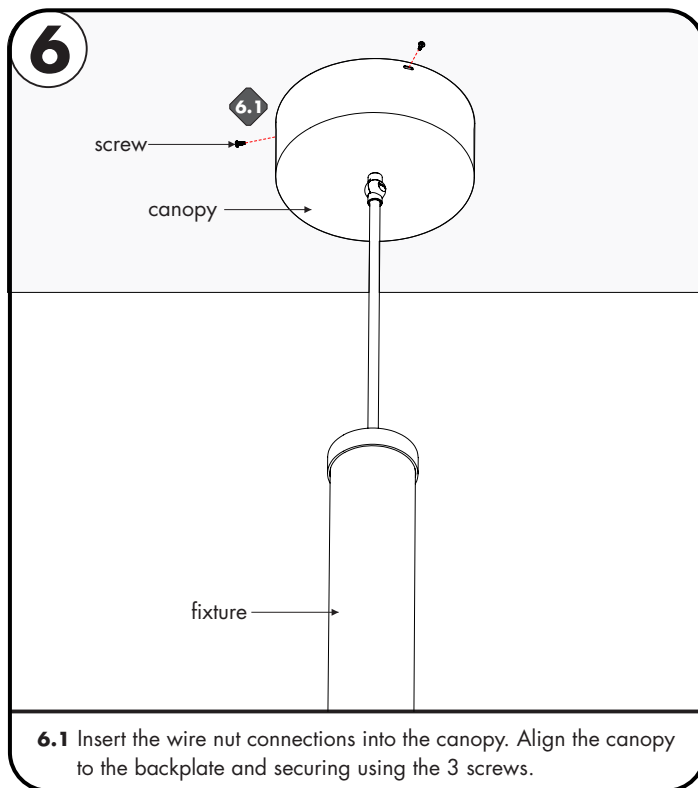
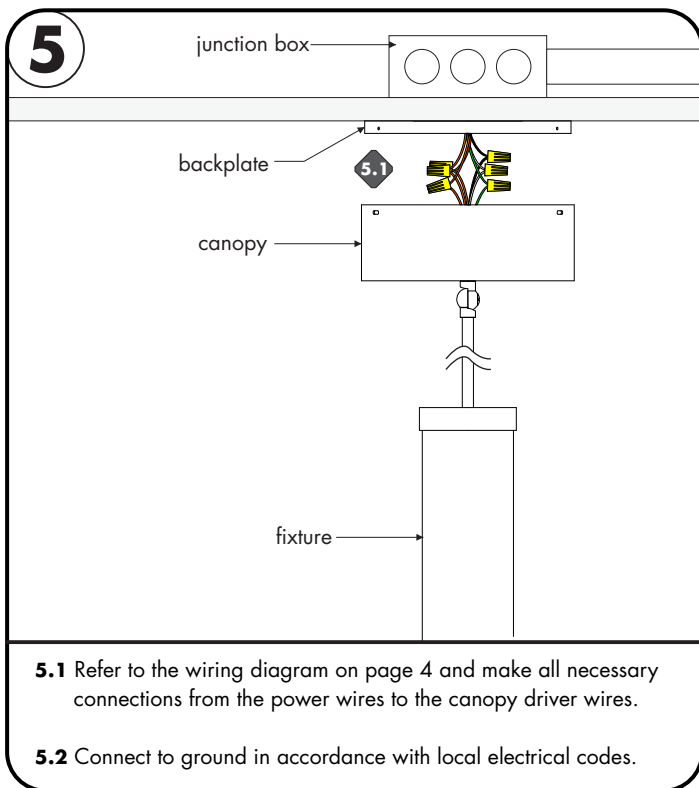

Installation Instructions for Scout Vertical

Models SCT-VRXX-XX

Please read all instructions prior to installation and keep for future reference!

1. Product to be installed by a qualified electrician.
2. Prior to installation ensure power is off at fuse box to prevent electrical shock.



7777 N. Merrimac Ave
Niles, IL 60714
T 224.333.6033
F 224.757.7557
info@luminii.com
www.luminii.com



Wiring Diagrams

Lutron Ecosystem H-series wire power supply wiring

to ecosystem bus

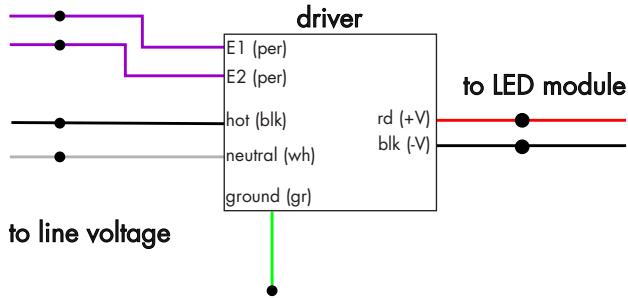

eldoLED Dali power supply wiring

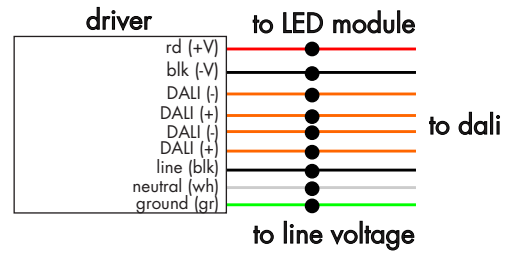

Lutron Ecosystem 3 wire power supply wiring

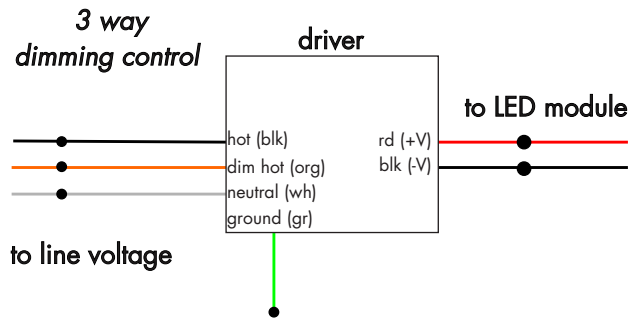

eldoLED 0-10V Dimming power supply wiring

